

MODEL	SC 200		SC 250		SC 325		
	MM	INCH	MM	INCH	MM	INCH	
Centre distance	750 / 1000	30" / 40"	1000 / 1500	40" / 60"	1000 / 1500 / 2000 / 3000	40" / 60" / 80" / 120"	
Centre height	200	8"	250	10"	325	13"	
Swing over bed	402	16"	502	20"	652	26"	
Swing over gap	560	22"	700	27 ½"	910	36"	
Gap length in front of face plate	120	5"	160	6"	220	9"	
Bed width	250	10"	300	12"	350	14"	
Swing over carriage	335	13"	440	17"	595	23"	
Swing over cross slide	245	9 ½"	310	12"	450	18"	
Cross slide travel	210	8"	250	9 ¾"	325	12 ¾"	
Tool post slide travel	105	4"	130	5"	155	6"	
Maximum tool dimensions	20 X 20	3/4" x 3/4"	25 X 25	1" x 1"	25 X 25	1" x 1"	
Headstock Main spindle bore	42	1 ½"	58   105	2 ½"   4"	80   155	3"   6"	
Main spindle nose / Camlock	A2 - 5 / 5		A2 - 6 / 6   A2 - 8 / 8		A2 - 8 / 8   A2 - 11 / 11		
Main spindle morse taper (MT)	4		4		5		
Speed range (rpm)	40 - 2800		40 - 2300		30 - 1700		
No. of speed range	3		3		3		
Speed range 1 (rpm)	40 - 345		40 - 310   85 - 200		30 - 240   50 - 120		
Speed range 2 (rpm)	345 - 1015		310 - 840   200 - 465		240 - 630   120 - 290		
Speed range 3 (rpm)	1015 - 2800		840 - 2300   465 - 1250		630 - 1700   290 - 800		
Norton box No. threads and feeds	44		44		55		
Longitudinal feeds	0.05 - 0.752		0.05 - 0.752		0.05 - 1.5		
Cross feeds	0.025 - 0.376		0.02 - 0.296		0.025 - 0.752		
Metric threads	0.5 - 7.5		0.5 - 7.5		0.5 - 15		
Whitworth threads in T.P.I.	60 - 4		60 - 4		60 - 2		
Modular threads	0.25 - 3.75		0.25 - 3.75		0.25 - 7.5		
Pitch diametral threads	120 - 8		120 - 8		120 - 4		
Ø35 lead screw rod pitch	6	1/4"	6	1/4"	6	1/4"	
Tail stock barrel diameter	58	2 ¼"	68	2 ½"	95	3 ¾"	
Tail stock barrel travel	180	7"	200	7 ¾"	220	8 ½"	
Tail stock morse taper (MT)	4		4		5		
Fixed Steady capacity	125	4 ¾"	145	5 ½"	185	7 ¼"	
Follow Rest capacity	90	3 ½"	95	3 ¾"	130	5"	
Main Motor Power (kw)	4		5.5		7.5		
Pump Motor Power (kw)	0.1		0.1		0.1		
Capacity of coolant tank (lts)	42 / 55		67 / 92		81 / 111 / 151 / 201		
Overall dimensions (mm)	Length	2115 / 2390		2700 / 3200		2700 / 3200 / 3800 / 4700	
	Width	910		950		1080 / 1110	
	Height	1625		1750		1825	
	Weight (Kg)	1030/1190		1520 / 1680		1750 / 2100 / 2500 / 3100	
Acceptance Accuracy	DIN 8605		DIN 8605		DIN 8605		

Specifications subject to change without notice. Not responsible for typographical error. Machines are shown with optional equipment.

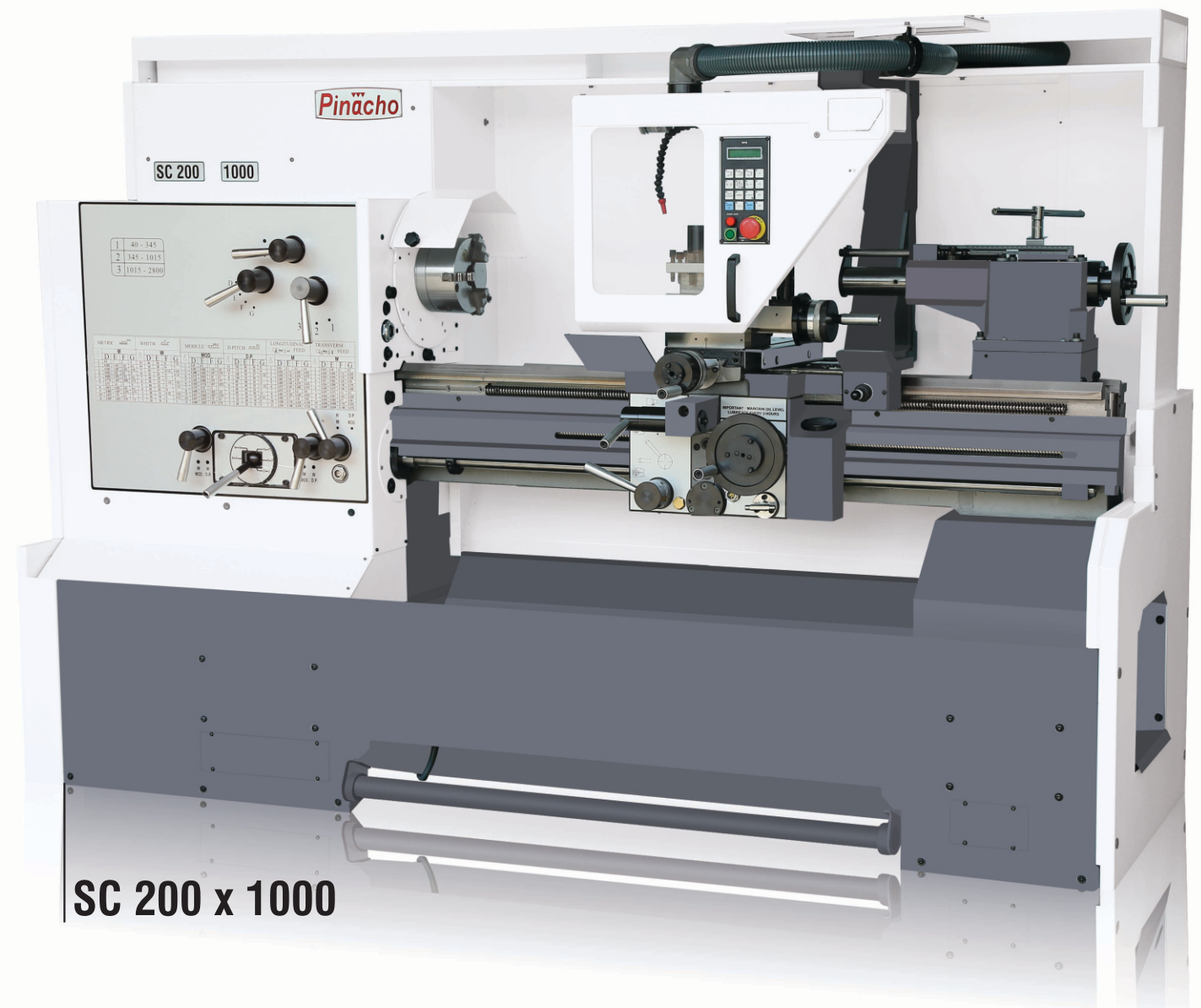

## NEW SERIES SC



CONVENTIONAL LATHE  
VARIABLE  
SPEED HEADSTOCK



### PINACHO

FABRICA DE MAQUINAS-HERRAMIENTAS  
PARTIDA DE LA SIERRA S/N, 22310 CASTEJON DEL PUENTE (HUESCA), SPAIN  
Phone : +34 974 401650 +34 974 416930 | Fax: +34 974 401654, +34 974 417733  
E-mail : europe@pinacholathescnc.com | Web : www.pinacholathescnc.com



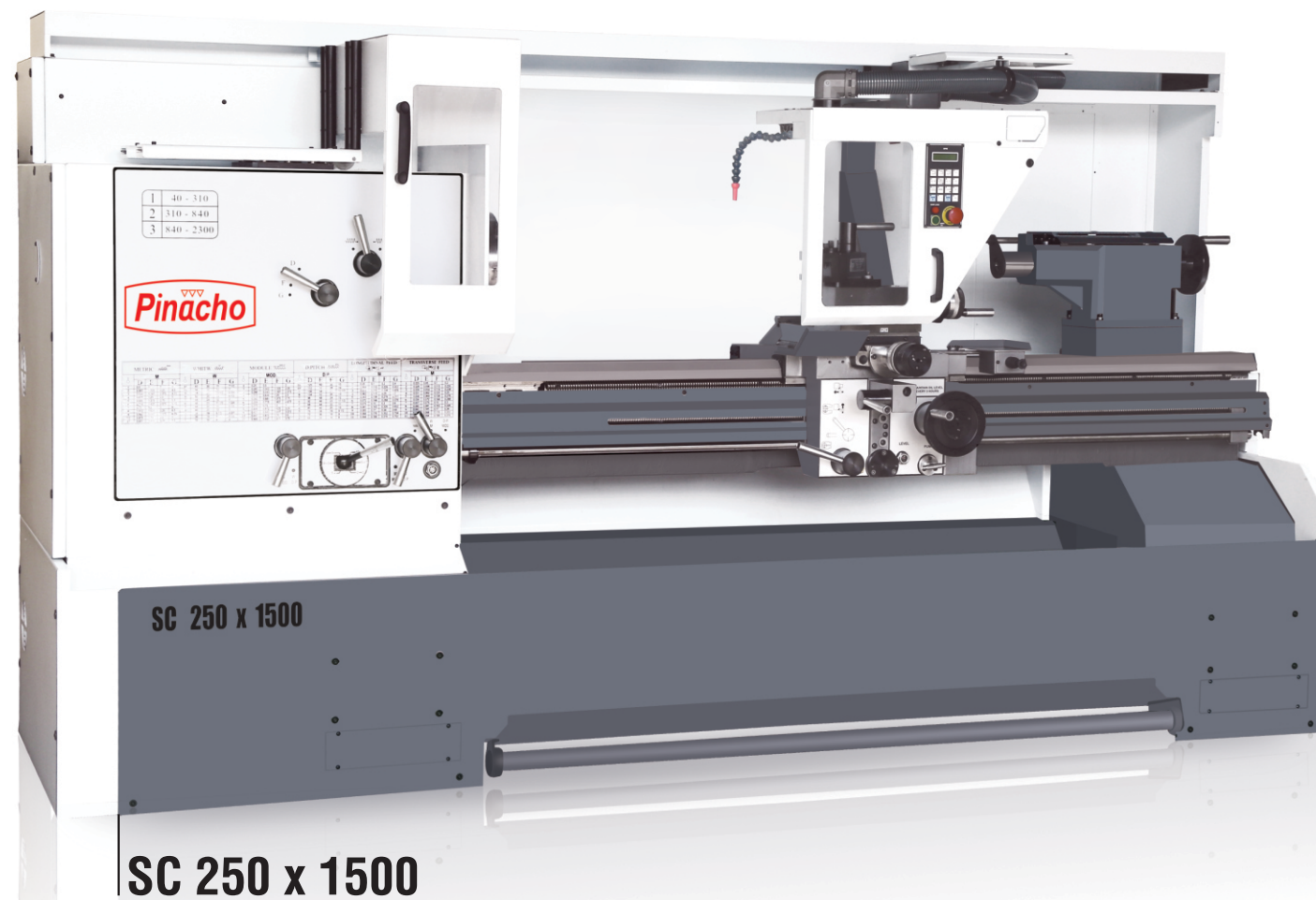

**SC 250 x 1500**

## DESCRIPTION

The combination of constant surface and electronically variable spindle drive SC gives the better cutting performance among the best lathes in the market. Combination of precision, power, durability and advance features ensure long - living performance. SC - the state of art technology makes it ideal for tool room and production applications with maximum precision, high productivity, long life to the machines.

## FEATURES

Constant power, 3 range variable speed  
 Ease of use and excellent assistance for high accuracy jobs  
 High chip removal rate during the rough turning operation  
 Induction Hardened & grounded guide ways

## BENEFITS

Very versatile for machining big and small components  
 Constant power in all rpm ranges  
 Very high production efficiency  
 Excellent quality finish with maximum precision

## Standard Accessories

- Spindle brake
- Main spindle reducing bush & fixed centre
- Tailstock reducing bush & fixed centre
- Square tool post and key
- Chip collecting tray
- Instruction manual
- Centralised lubrication
- Coolant equipment
- Reducing bush
- Rear splash guard
- Top Slide guard
- Rigid lead screw guard
- Levelling plates
- Chuck guard with limit switch
- Emergency stop
- Main switch
- Work light
- C E Compliant

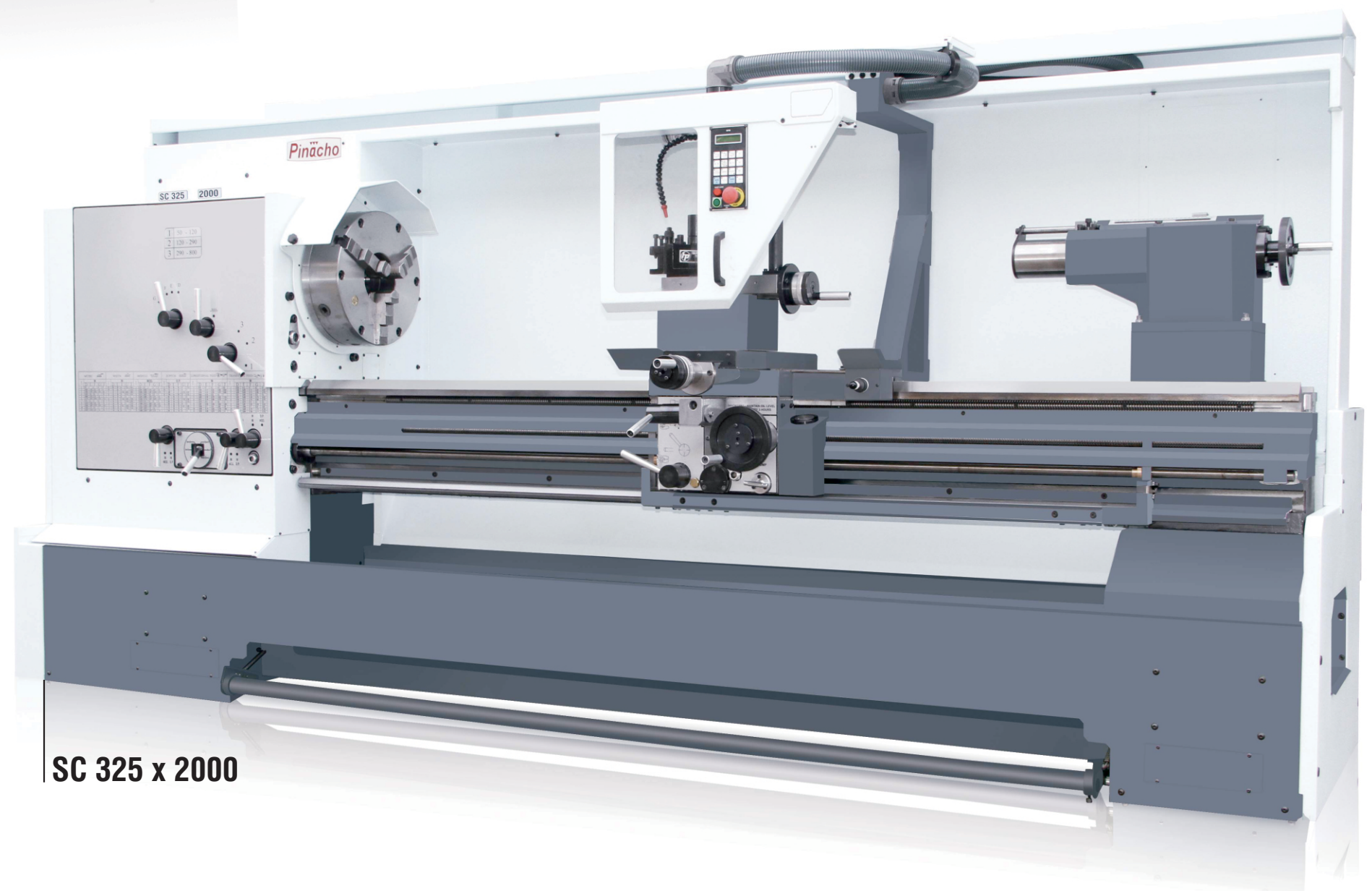

**SC 325 x 2000**